



A2 Multitrac

with A2 Welding Controller PEI

The universal welding automat for better welding economy

The A2 Multitrac is the result of years of experience and the latest technology. The A2 Multitrac is designed to put your welding operation on the right track to increase productivity and quality, whether you work with SAW single or twin or with MIG/MAG welding.

The compact and efficient design makes it easy to move the A2 Multitrac from one place to another and between different welding workpieces.

The heavy dimensioned feed units secure an even and stable wire feed, a pre-requisite for top quality, homogeneous welding.

The carriage of the tractor is four-wheel driven which ensures a constant and stable welding speed even in inclined positions. The carriage is equipped with a handle to disengage the gear and the A2 Multitrac can then easily be pushed to another place.

The A2 Multitrac for Submerged Arc Welding can be delivered in two versions, for single or twin wire. When using twin wire the deposit rate is increased by 30-40%. Joint gaps can easily be bridged and there is less risk for burn through. When cladding, the A2 Multitrac with twin wire can easily be set up for low penetration.

Accessories

To be able to increase the profitability, there are a number of accessories: specially developed idling rollers, guide wheel bogies



in V-joint keeps the tractor on track along the joint. The guide wheel bogies can also be used for inside tube welding.

V-guide wheels for guide rail when the welding workpiece lacks a guiding edge when an I-joint is to be welded. Pilot lamps with a light bulb or a laser diode, which projects a luminous spot in the joint.

A2 welding controller

The control equipment is very easy to use with a minimum of training. The welding parameters are adjusted by turning knobs and the actual parameters are shown on the digital displays. With the controller the user can choose between different start methods, direct start or scratch start. The burnback time is also easily adjustable to optimise the stops for different size of wire.

Technical data

		Single SAW	Twin SAW	GMAW
Wire dimensions (mm)	Steel	1.6-4.0	2 x 1.2-2.5	0.8-1.6
	Stainless	1.6-4.0	2 x 1.2-2.5	0.8-1.6
	Cored wire	1.6-4.0	-	1.2-2.4
	Aluminium	-	-	1.2-1.5
Max wire feed speed (m/min)		9	9	16
Electrode weight (kg)		30	2 x 15	30
Flux volume (l)		6	6	-
Weight excl. wire and flux (kg)		47	47	43
Permissible load 100% (A)		800	800	600
Control voltage (V)		42	42	42
Travel speed (m/min)		0.1-1.7	0.1-1.7	0.1-1.7
Linear slides setting length (mm)		90	90	90
Rotary slide setting angle (°)		360	360	360

Ordering information

A2 Multitrac SAW	0449 360 880
A2 Multitrac SAW Twin	0449 360 881
A2 Multitrac GMAW	0449 361 880

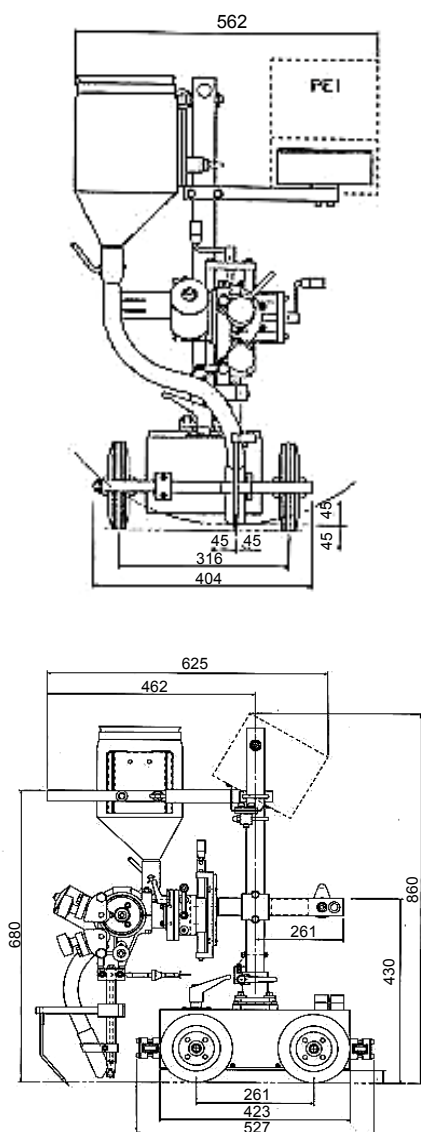

Accessories

		Single SAW	Twin SAW	GMAW
Contact tips Ø				
M12				
1.6 mm	0154 623 008	X		
2.0 mm	0154 623 007	X		
2.5 mm	0154 623 006	X		
3.0 mm	0154 623 005	X		
4.0 mm	0154 623 003	X		
M10				
1.6 mm	0258 000 909			X
2.0 mm	0258 000 910			X
2.4 mm	0258 000 911			X
3.2 mm	0258 000 915			X
Adapter M6/M10	0147 333 001			X
M6				
0.8 mm	0153 501 002			X
1.0 mm	0153 501 004			X
1.2 mm	0153 501 005		X	X
1.6 mm	0153 501 007		X	X
2.0 mm	0153 501 009		X	
2.4 - 2.5 mm	0153 501 010		X	
Feed rollers Ø				
0.8 mm	0145 538 881			X
1.0 mm	0145 538 882			X
1.2 mm	0145 538 883			X
1.6 mm	0218 510 281	X		
2.0 mm	0218 510 282	X		
2.4-2.5 mm	0218 510 283	X		
3.0-3.2 mm	0218 510 298	X		
4.0 mm	0218 510 286	X		
Knurled feed rollers for cored wire Ø				
0.8-1.6 mm	0146 024 880	X		X
2.0-4.0 mm	0146 024 881	X		X
Knurled pressure rollers Ø				
0.8-1.6 mm	0146 025 880	X		X
2.0-4.0 mm	0146 025 881	X		X
Shaft for knurled pressure roller	0212 901 101	X		X
Feed rollers for Twin Ø				
2 x 1.2 mm	0218 522 486		X	
2 x 1.6 mm	0218 522 488		X	
2 x 2.0 mm	0218 522 484		X	
2 x 2.4 - 2.5 mm	0218 522 480		X	
Auxiliary guiding equipment				
Guide wheel bogie	0413 542 880	X	X	X
Idling roller	0333 164 880	X	X	X
Guide bar 3 m	0154 203 880	X	X	X
V-guide wheel	0333 098 881	X	X	X
V-wheel track in steel (4 pcs)	0443 682 881	X	X	X
Loop for connection of two automats	0334 680 881	X	X	X
Flux handling equipment				
Flux recovery unit OPC	0148 140 880	X	X	
Bracket suction	0332 947 880	X	X	
Flux hopper of silumin alloy	0413 315 881	X	X	
Concentric flux feeding funnel	0145 221 881	X	X	
Contact tube, bent	0413 511 001	X	X	
Gas handling equipment				
Cooling unit OCE2, 220V, 50/60 Hz	0414 191 881			X
Hose (gas) *	0190 270 101			X
Hose (cooling water) *	0190 315 105			X
Arc shield	0334 689 880			X
*) Number of meters to be specified				
Completion set Twin Arc	0413 541 882	X		
Wire reel				
Wire reel, plastic 30 kg	0153 872 880	X	X	
Wire reel, steel, fixed width	0416 492 880	X	X	
Wire reel, steel, flexible width	0449 125 880	X	X	
Wire reel, steel, Ø 220 mm	0671 164 080	X	X	

ESAB reserves the right to alter specifications without prior notice
ESAB is approved according to ISO 9001:2000



ESAB AB
Welding Equipment
SE-695 81 LAXÅ SWEDEN
Phone: +46 584 81000
Fax +46 584 12577
www.esab.com



ESAB 1904
A CENTURY OF INNOVATION