



# Miggytrac 2000

*The perfect complement to your MIG/MAG power source*

**The Miggytrac 2000 is a superb alternative if you wish to automate your GMAW process. It is ideal for long welds as it eliminates stressful welding positions for welders. The Miggytrac is ideally suited for use with ESAB's semi-automatic power sources and feed units.**

The Miggytrac 2000 is a small, compact, motor powered tractor to which a standard ESAB welding torch can be attached quickly. The four driving wheels, together with the permanent magnet which is fitted on the tractor, guarantee even, stable movement. The magnet helps to hold the tractor in the correct position on the workpiece, even if it is bent or angled. The magnet can be switched on/off when moving the tractor to another workplace.

The Miggytrac 2000 is using guide wheels to follow the joint. The guide wheels can be adjusted to allow the unit to drive itself against the workpiece. The tractor functions as a straightforward remote control for the feed unit; you decide on the travel direction, then start and stop welding from the panel. The panel features additional functions such as weld speed settings (15-150 cm/min), wire feed speed and voltage.

The tractor can be programmed for intermittent welding. The length of the weld and the distance between the welds can be set to 1-99 cm. The travel between the welds are high speed 250 cm/min to increase efficiency.

Miggytrac 2000 has also a backfill function where the tractor reverse at the end of the weld to fill a possible crater.



Cored-wire welding - a process in keeping with the times

It is easy to mechanise a semi-automatic welding machine using the Miggytrac 2000. The welding speed can be increased significantly, especially when cored wire is used. Simply connect the tractor to a suitable semi-automatic power source with a feed unit. Alternatively, an external transformer can be connected. The automatic welder performs the long and monotonous weld runs.

The torch holder

The torch holder is equipped with one manual slide ( $\pm 17$  mm) for fine corrections of the torch position. The torch holder has also a rotating slide which gives maximum opportunities to get the best possible torch angle. The handle is positioned to make it easy for the user to carry the machine between the welds.

## Technical data

Control voltage	36 - 46 V AC
Power	40 W (max)
Welding speed	15 - 150 cm/min
Fast travel speed	250 cm/min
Programmable interval welding	1 - 99 cm
Adjustment of slide	+/- 17 mm
Remote control outlet	Volt and ampere (wire feed speed)

Connection	Burndy, 12 pins
Crater fill time	0-9.9 s
Backfill	0-9.9 cm
Dimensions (LxWxH)	330x260x360
Weight	9.5 kg

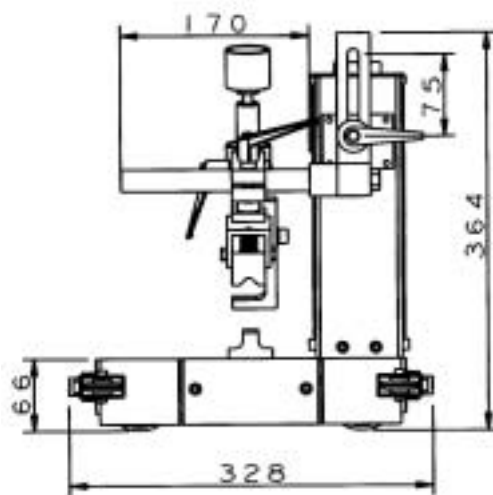
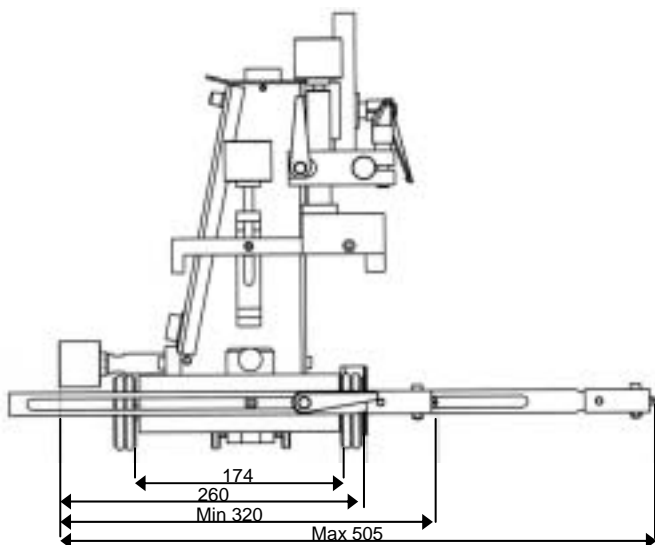

## CABLE KEY DIAGRAM

Feeder unit	Brand	0457 360 880	0457 360 881	0457 360 883	0457 462 880	0443 341 880	0459 681 880	0457 467 880	Voltage	Current	Power	On/Off
Origo™ Feed 304; M12	ESAB	X							-	X	X	X
Origo™ Feed 484; M12		X							-	X	X	X
Origo™ Feed 304; M13		X							X	X	X	X
Origo™ Feed 484; M13		X							X	X	X	X
Aristo™ Feed 3004, 4804		X					X		X	X	X	X
MEK 4		X			X				X	X	X	X
MEH 44	ESAB			X		X			X	X	X	X
Universal	?		X					X	?	?	X	X
		Cable 23 pins	Cable without plug	Cable 4 pins + 12 pins	Cable kit	Connection kit	Remote adapter kit	Transformer				

Miggytrac 2000

## Ordering information

Miggytrac 2000	0457 358 880
Welding screen	0457 463 881

Remote control of voltage and current only when connected to a suitable power source/wire feed unit. The cable must be ordered as the cable key diagram shows.



ESAB AB  
Welding Equipment  
SE-695 81 LAXÅ SWEDEN  
Phone: +46 584 81000  
Fax: +46 584 411721  
E-mail: info@esab.se  
www.esab.com

